

ClearLock 637



Technical Manual
(English Version)

Rev 00

DOCUMENT REVISION

| REV. | DATE | WRITER | CHECKED BY | SUBJECT |
|------|---------|--------|------------|---------------|
| 00 | 03/2016 | SLU | | FIRST EDITION |

TABLE OF CONTENTS

| | |
|---|-----------|
| 1. SAFETY WARNINGS..... | 4 |
| 2. ELECTRONIC MAIN BOARD..... | 5 |
| 2.1. CONNECTIONS TO THE MAIN BOARD | 6 |
| 2.2. BLOCK DIAGRAM | 7 |
| 2.3. POWER SUPPLY | 8 |
| 2.4. SUN ANTENNA MAIN BOARD | 9 |
| 2.5. CONNECTIONS (MAIN BOARD) | 10 |
| 2.6. WEIGHT SYSTEM CONNECTION DIAGRAM | 17 |
| 2.7. AUXILIARY BOARD I/O 315 CONNECTION DIAGRAM | 18 |
| 2.8. EQ-34 SENSOR ADJUSTMENT..... | 19 |
| 2.9. INTERNAL INTERCOM PORTER..... | 19 |
| 3. PROGRAMMING AND ANALYSIS | 20 |
| 3.1. COMPUTER CONNECTION DIAGRAM - MAIN BOARD..... | 21 |
| 3.2. COMPUTER CONNECTION DIAGRAM - METAL DETECTOR | 21 |



PLACING AND MAINTENANCE

This handbook must be used only by qualified technicians and authorised by **Automatic Systems**

1. SAFETY WARNINGS

- This manual must be made available to any person who works with the equipment, e.g., installers, maintenance technicians, end users, etc.
- This equipment has been designed to control and manage pedestrian access and flow and cannot be applied to any other use without risk to users or to the integrity of the equipment.
Automatic Systems cannot be held responsible for damages caused by improper use of the equipment.
- It is strongly recommended that children be supervised as they pass through the door. Extreme care is also required with animals, which should be kept on a leash and under the control of their owners.
- Do not add non-approved accessories (contact between different metals causes an electrolytic effect that decreases the equipment's corrosion resistance or a malfunction of the metal detector).
- The Contractor shall comply with local standards when installing the equipment.
- Any work on the equipment must be performed by qualified personnel. **Automatic Systems** shall reserve the full right to automatically refuse our warranty if any unauthorized work or work performed by an unqualified technician is performed on this product.
- Access to the mechanism is reserved for personnel who are aware of the electrical and mechanical dangers in the case of negligent operation. This personnel is obliged to close off access to the mechanical equipment after completing any work.
- For any operation that does not require the equipment to be powered on, disconnect the electrical power using the **SYSTEM** switch on the console to **OFF** (or open the breaker on the client distribution panel) **AND** disconnect the batteries.
- Any internal element that may be live or that could move should be handled with caution.
- The equipment is factory configured in "minimal risk" mode for its users. Parameters should only be changed by qualified personnel with full knowledge of the consequences, and this shall in no way entail any liability on the part of **Automatic Systems**.
- The equipment must be completely visible to the user/operator before being put into operation.
- After a collision, even if there is no visible damage, the equipment must be checked by a qualified technician.
- Especially for booth product:
 - Not walk on the booth's roof.
 - Do not close circuit the batteries.
 - Before moving the booth make sure that the weight basket is anchored to the casing with the blocking system.
 - Always place the protection guard behind the panel after maintenance.
 - There is a small internal panel where the main switch can be accessed and the security system can be adjusted.
 - After unpacking and before you proceed to assemble the booth, put away all the material in a dry and clean place.

2. ELECTRONIC MAIN BOARD

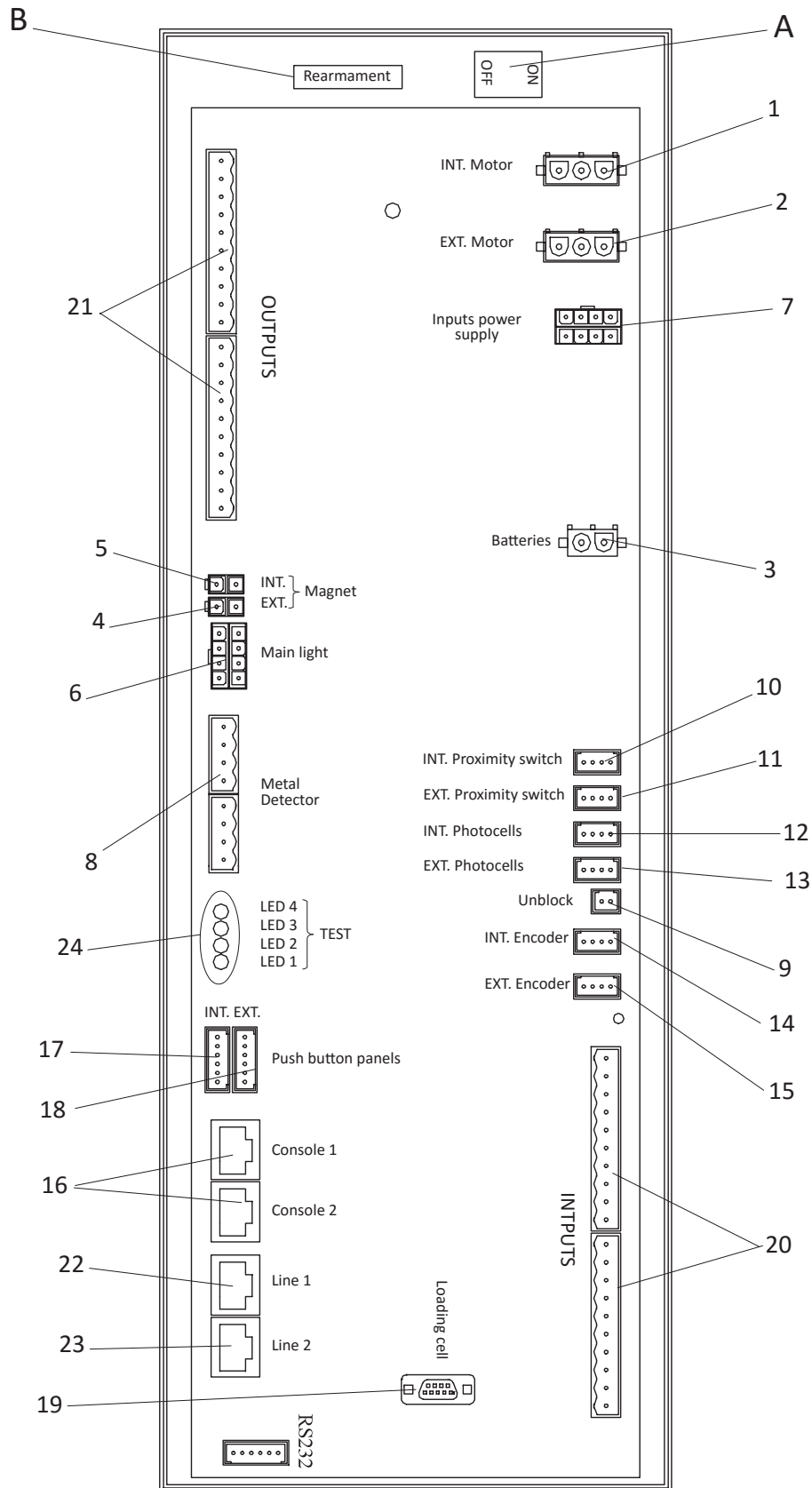

The information contained in this document is the property of Automatic Systems and is confidential. The recipient shall refrain from using this information for any purpose other than the use of the products or the execution of the project to which it refers and from communicating it to third parties without prior written agreement of Automatic Systems. The document is subject to change without notice.

2.1. CONNECTIONS TO THE MAIN BOARD

- A Booth's ON/OFF switch.
- B Re-able switch with emergency batteries after discharging.
- 1 Cable cv02A connection to the internal motor.
- 2 Cable cv01A connection to the external motor.
- 3 Cable cv03B connection to emergency batteries.
- 4 Cable cv07B connection to the unblock magnet for the internal door emergency.
- 5 Cable cv07A connection to the unblock magnet for the external door emergency.
- 6 Cable cv06A connection to the voice message speaker.
Cable cv13A connection to the spotlight.
Cable cv14A connection to the intercom's call button (main push button panel) CE.
- 7 Cable cv08A power connection.
- 8 Cable cv12A connection to the metal detector's main board.
- 9 Cable cv14A connection to the emergency button (main push button panel) CE.
- 10 Cable cv11A connection to the internal proximeter.
- 11 Cable cv10A connection to the external proximeter.
- 12 Cable cv17A connection to the door's external rubber side contact.
- 13 Cable cv18A connection to the internal rubber side and main board power contact.
- 14 Connection with encoder cable to internal encoder.
- 15 Connection with encoder cable to external encoder.
- 16 Cable cv19A connection to the console.
- 17 Cable cv05A connection to the internal push button panel.
- 18 Cable cv04A connection to the external push button panel.
- 19 Connection with loading cell cable to loading cell.
- 20 Input connections:
 - Clamps 1 and 3 activating bridge.
 - Clamps 11 and 12 cable cv09A connection to mechanical lock.
 - Clamps 15 and 20 first entrance bridge.
- 21 Exit connections.
- 22 Cable 5806791 connection to the SUN system (only booth's with Sun system).
- 23 Cable 5806791 connection to the SAIMA metal detector with digital console.
- 24 Auto diagnostic led.

2.2. BLOCK DIAGRAM

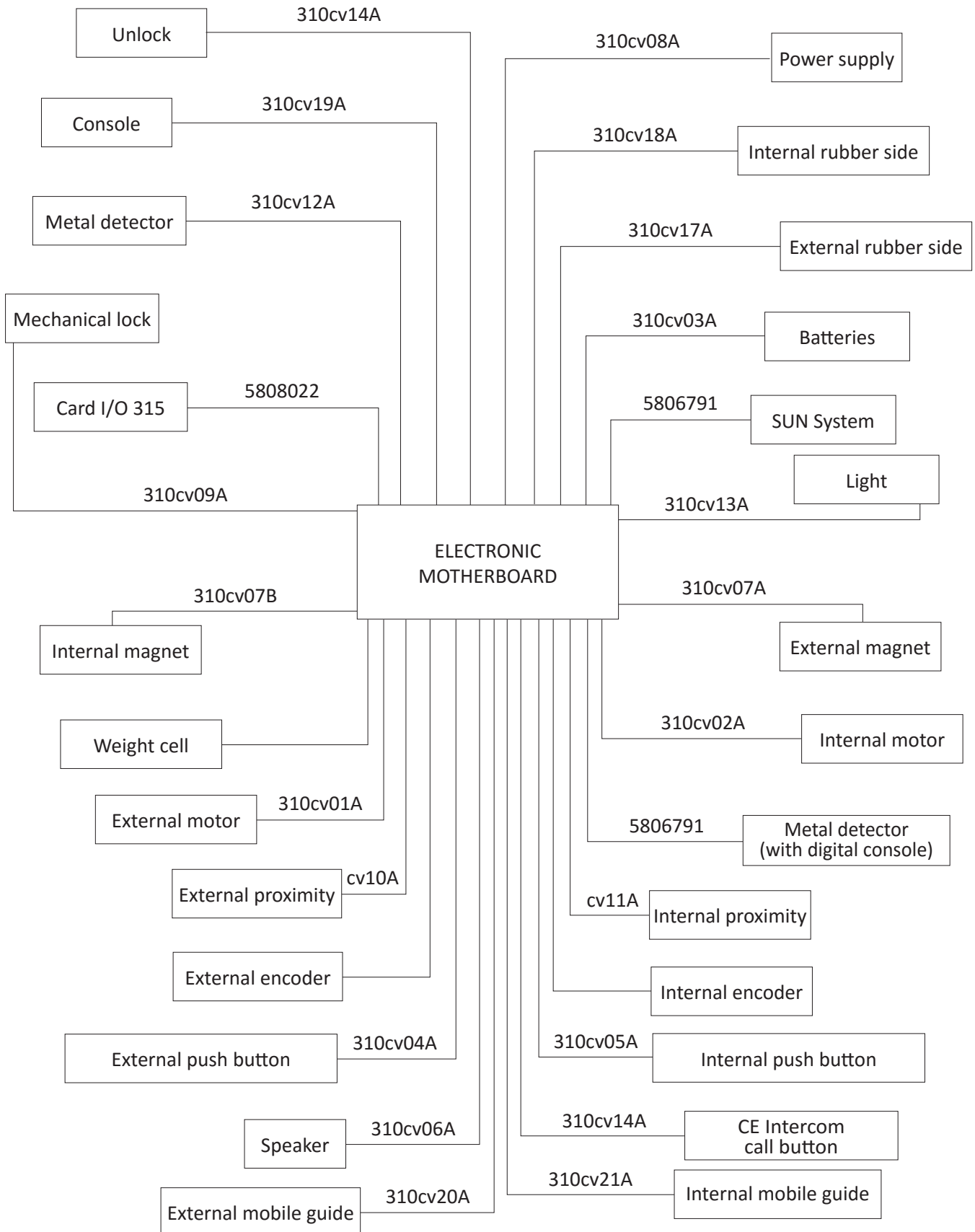

The information contained in this document is the property of Automatic Systems and is confidential. The recipient shall refrain from using this information for any purpose other than the use of the products or the execution of the project to which it refers and from communicating it to third parties without prior written agreement of Automatic Systems. The document is subject to change without notice.

2.3. POWER SUPPLY

2.3.1. Front side view

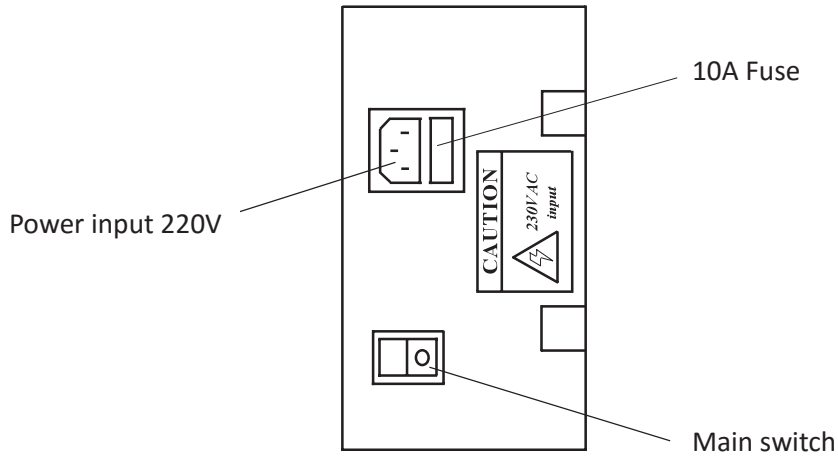

2.3.2. Back side view

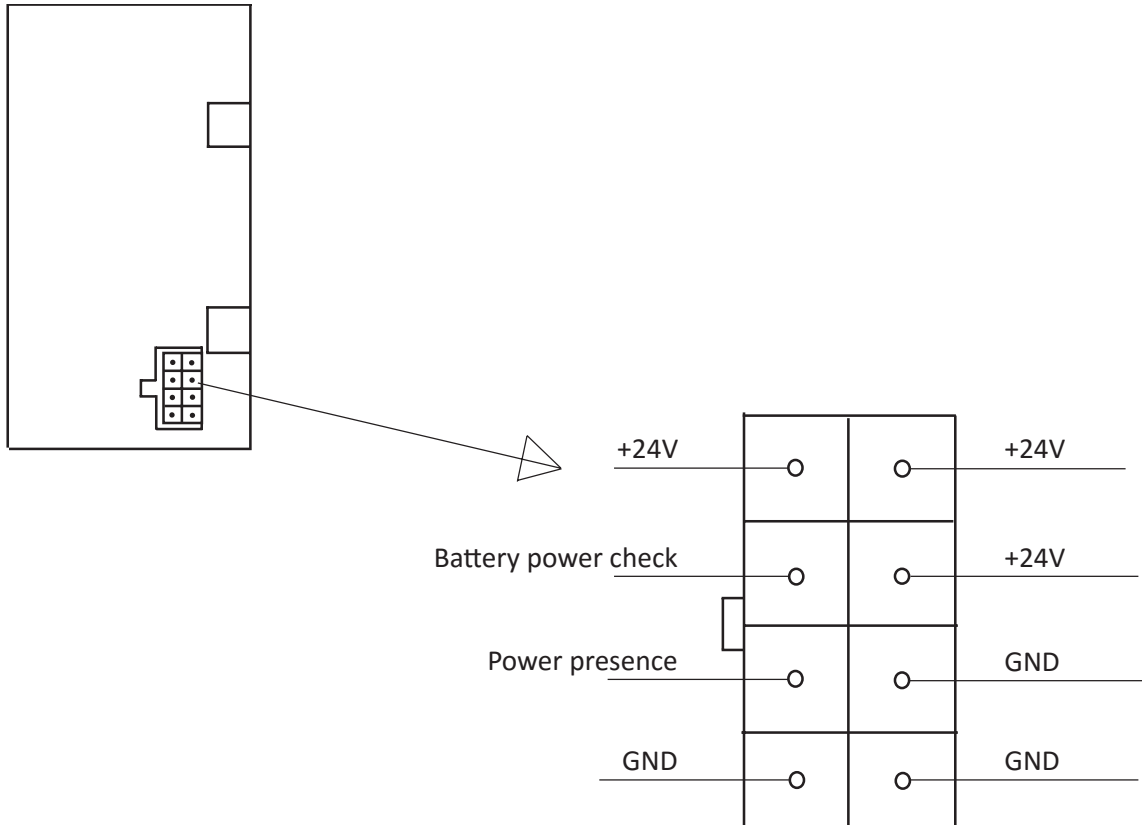

2.4. SUN ANTENNA MAIN BOARD

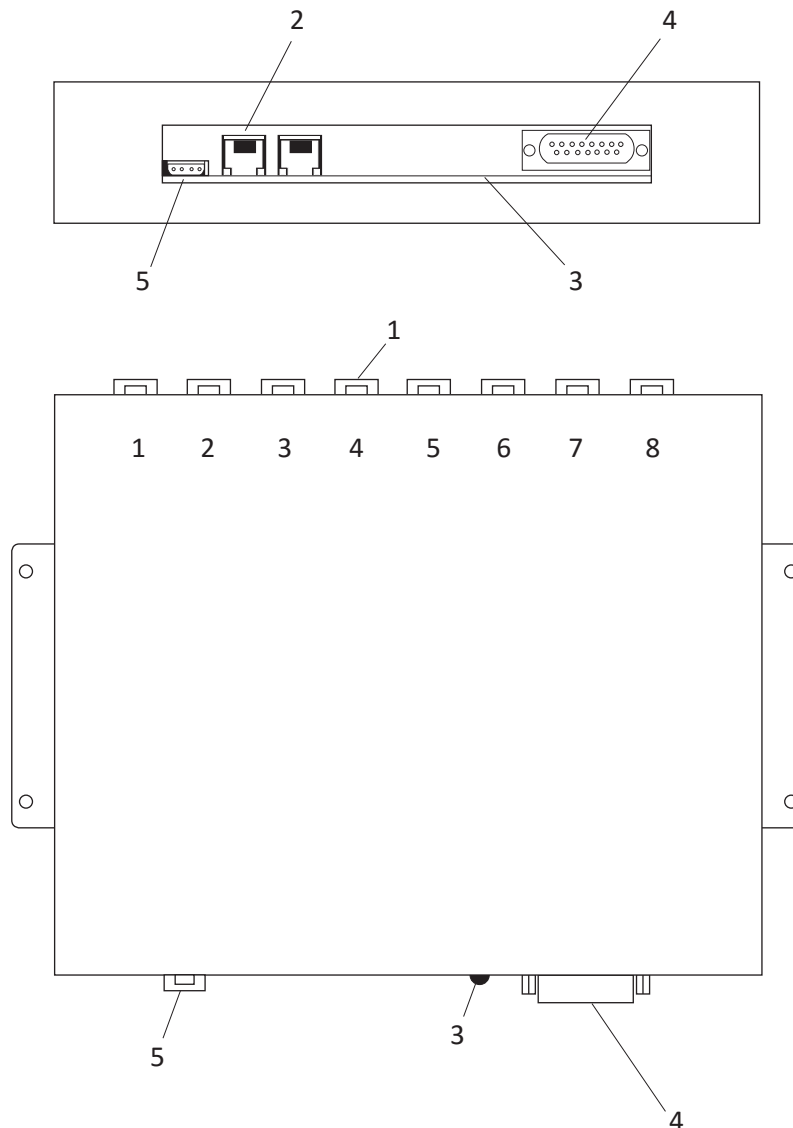

- 1 - SUN antenna's connectors.
- 2 - SUN amin board connecting plug - single card.
- 3 - SUN system functioning led (if the led flashes at a frequency of 1 second, the system is working properly).
- 4 - 5 - Not used.

2.5. CONNECTIONS (MAIN BOARD)

2.5.1. Motors

2.5.1.1. Internal door motor

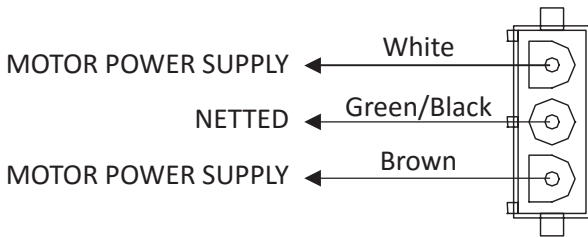

2.5.1.2. External door motor

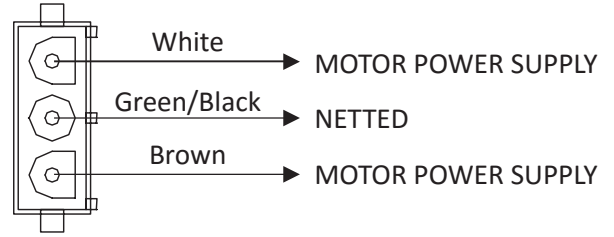

2.5.1.3. Batteries

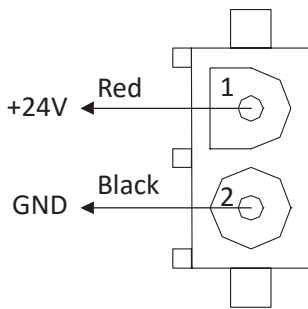

2.5.1.4. Int. magnet

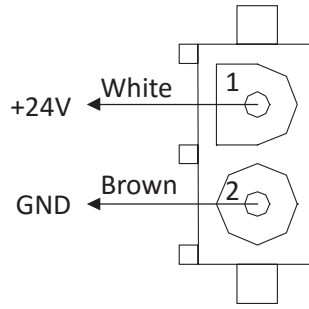

2.5.1.5. Ext. magnet

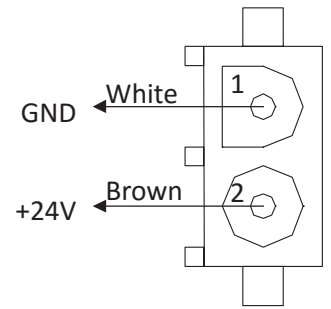

2.5.1.6. Ceiling light

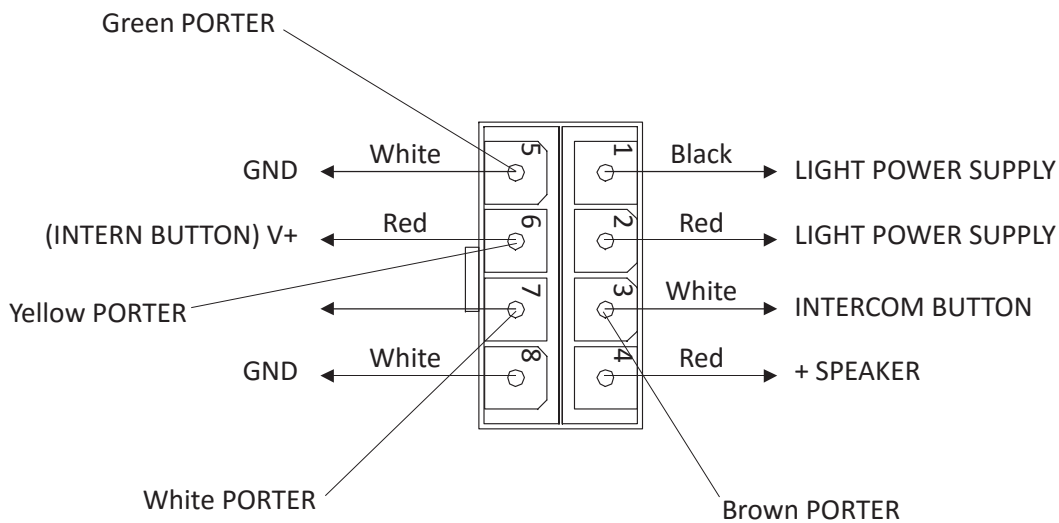

2.5.1.7. Power supply

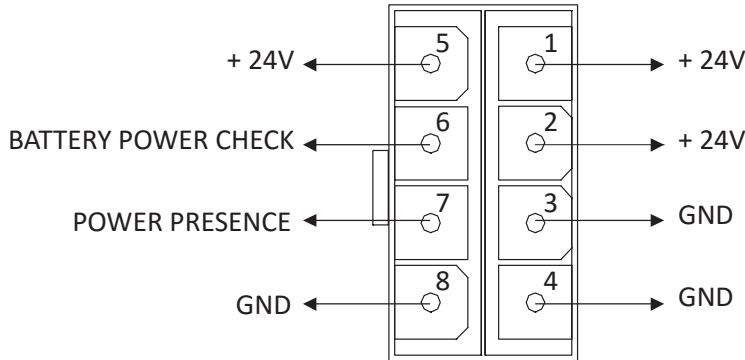

2.5.1.8. Metal Detector

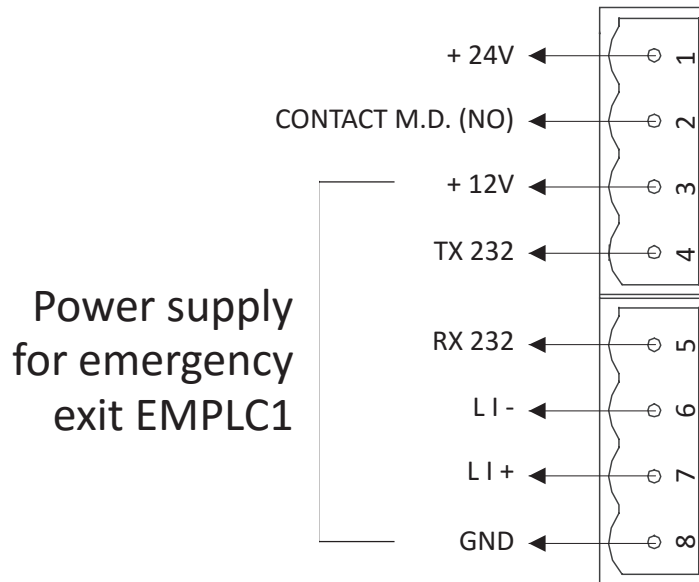

2.5.1.9. Unblock

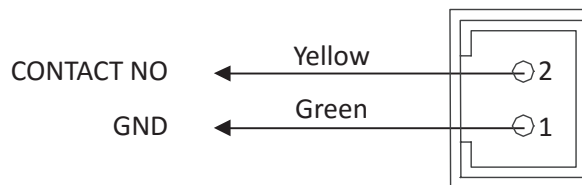

2.5.1.10. INT. proximity switch

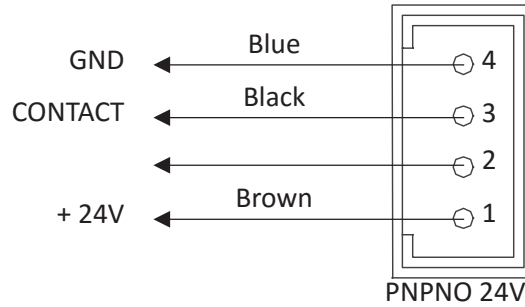

2.5.1.11. EXT. proximity switch

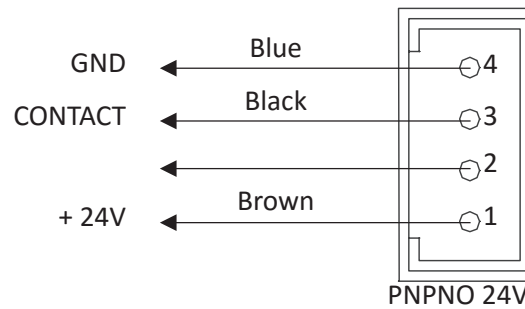

2.5.1.12. INT. accident prevention photocell

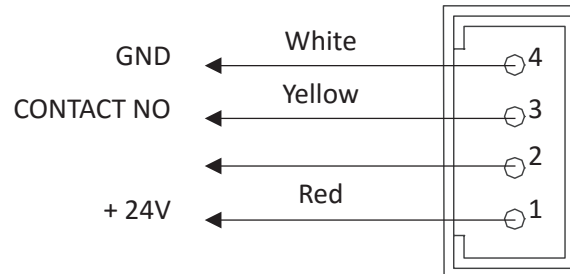

2.5.1.13. EXT. accident prevention photocell

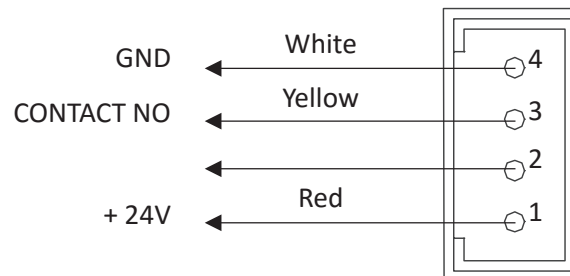

2.5.1.14. INT. encoder

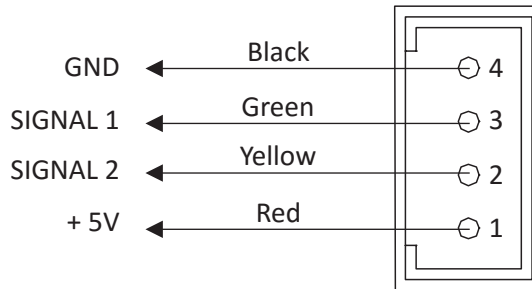

2.5.1.15. EXT. encoder

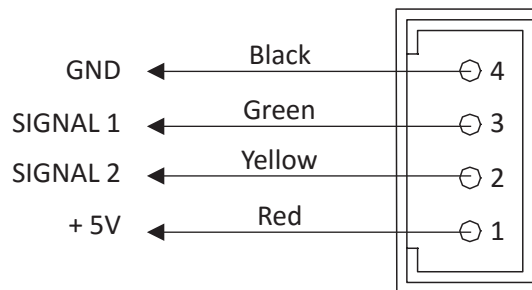

2.5.1.16. Main Console

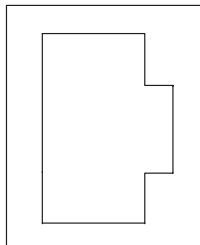

2.5.1.17. INT. push button panel

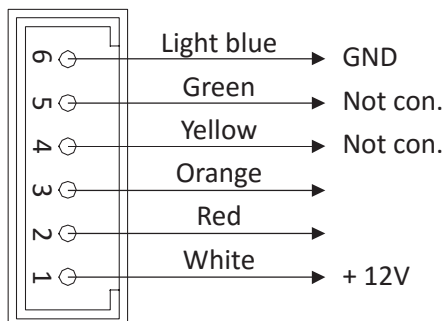

2.5.1.18. EXT. push button panel

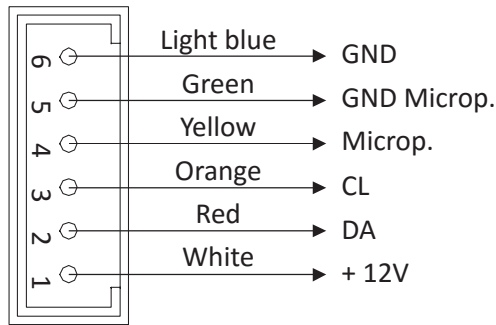

2.5.1.19. Loading cell

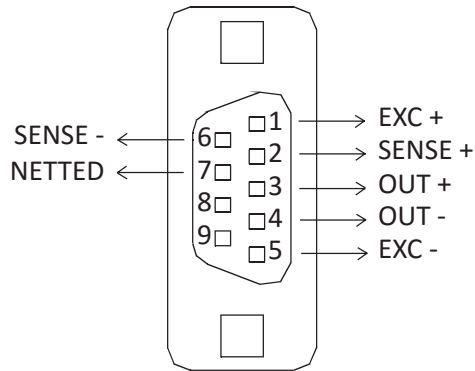

2.5.1.20. Inputs

| N° | NAME | ORDER |
|----|------------|---|
| 1 | IN 6 | ON (CONTACT NC) |
| 2 | IN 7 | PERSON SENSOR |
| 3 | + 24V | ON (COMMON) |
| 4 | GND | NOT USED |
| 5 | + 12V | NOT USED |
| 6 | + 12 V EXT | PHOTO COUPLERS |
| 7 | IN 8 | RUBBER SIDE OPENING |
| 8 | IN 9 | EXT. UNLOCKED |
| 9 | IN 10 | INT. UNLOCKED |
| 10 | IN 11 | M.D. EXCLUSION FOR ONE PASSAGE |
| 11 | + 24V | MECHANICAL LOCK (CONTACT C) |
| 12 | IN 0 | MECHANICAL LOCK (CONTACT NO) |
| 13 | IN 1 | AUXILIARY INPUT METAL ALARM (SEE ALSO METAL CONNECTOR) |
| 14 | + 24V | FIRST ENTRANCE KEY (CONTACT C) |
| 15 | IN 2 | FIRST ENTRANCE KEY (CONTACT NC) |
| 16 | IN 3 | INTERNAL RADAR OR BADGE (CONTACT NO) |
| 17 | + 24V | RADAR (COMMON) |
| 18 | IN 4 | EXTERNAL RADAR OR BADGE (CONTACT NO) |
| 19 | IN 5 | POST KEY (CONTACT NC) |
| 20 | + 24V | POST KEY (CONTACT C) |

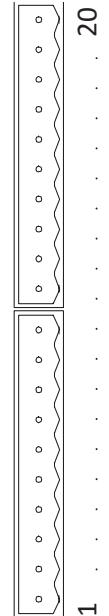

INPUT CONNECTORS

2.5.1.21. Outputs

| N | NAME | ORDER |
|----|-----------|---|
| 1 | GND | NOT USED |
| 2 | OUT 8 | CAMERA CYCLE |
| 3 | GND | NOT USED |
| 4 | OUT 7 | M.D. BLOCK CEIA |
| 5 | GND | NOT USED |
| 6 | OUT 6 | PERSON PRESENCE |
| 7 | GND | NOT USED |
| 8 | OUT 5 | NIGHT FUNCTION |
| 9 | GND | NOT USED |
| 10 | + 12V OUT | PROTECTED POWER SUPPLY 12V (EXTERNAL USE) |
| 11 | GND | OUTSIDE GROUND |
| 12 | OUT 3 | NOT USED |
| 13 | GND | NOT USED |
| 14 | + 24V OUT | PROTECTED POWER SUPPLY 12V (EXTERNAL USE) |
| 15 | GND | OUTSIDE GROUND |
| 16 | OUT 1 | NOT USED |

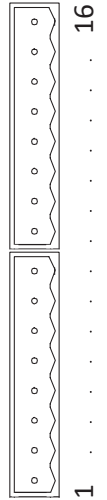

OUTPUT CONNECTORS

2.5.1.22. Line 1 (SUN SYSTEM where used)

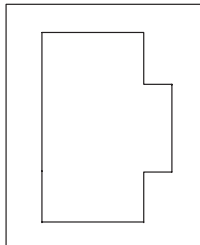

2.5.1.23. Line 2 (Metal Detector with digital console)

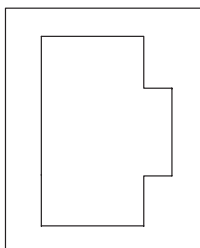

2.5.1.24. Auto diagnostic led

| LED CONDITION | MEANING |
|---------------|--------------------------|
| OLD 1 ON | ENCODER ERROR |
| OLD 2 ON | WEIGHT ERROR |
| OLD 1 & 2 ON | ONE RUBBER SIDE EXCLUDED |
| OLD 3 ON | MICRO POSITION ERROR |
| OLD 1 & 3 ON | ENCODER DIRECTION ERROR |

2.6. WEIGHT SYSTEM CONNECTION DIAGRAM

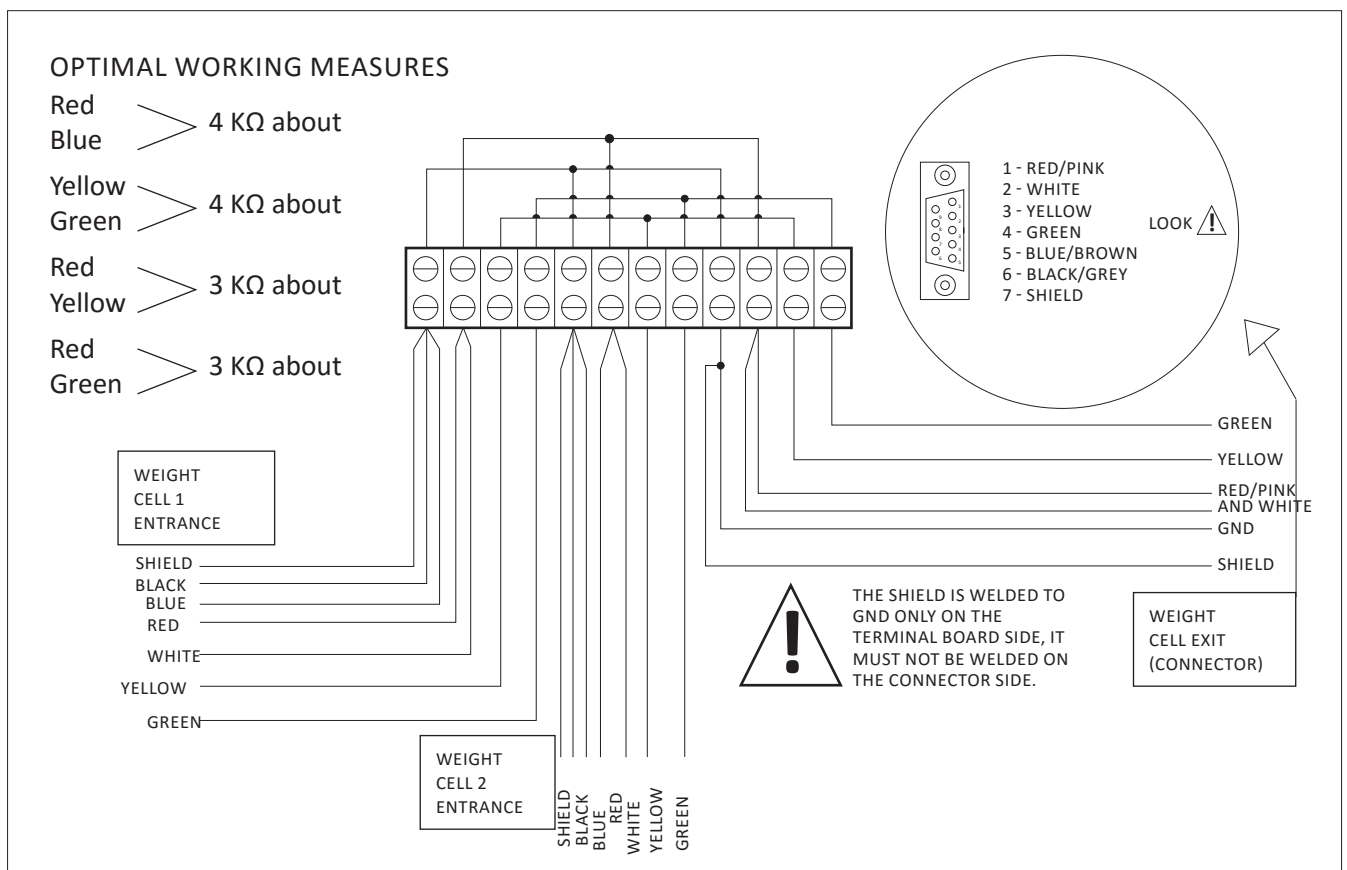

2.7. AUXILIARY BOARD I/O 315 CONNECTION DIAGRAM

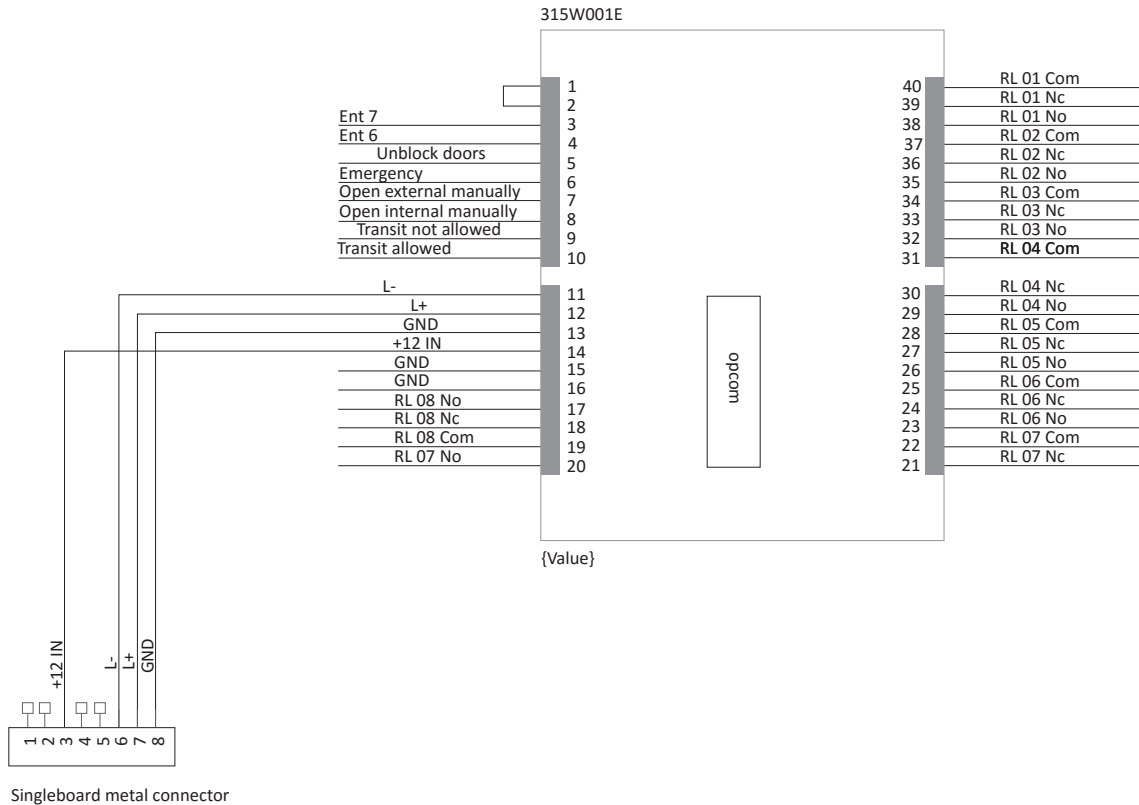

RL 01 Transit validation in entrance.

RL 02 Transit validation in exit.

RL 03 Booth contact in emergency.

RL 04 Internal door contact condition.

RL 05 External door contact condition.

RL 06 Excessive weight signal.

RL 07 Intercom signal.

2.8. EQ-34 SENSOR ADJUSTMENT



X

The EQ-34 sensor must be adjusted (tare) with the “X” trimmer.
With the aid of a white sheet it is possible to measure the dimension of the beam which must be adjusted to a maximum of 30 cm from the ground.

2.9. INTERNAL INTERCOM PORTER



By pushing the key with the bell inside the booth, the intercom porter is activated (placed on the ceiling of the booth) enabling communication with the console.

3. PROGRAMMING AND ANALYSIS

Testing for bad or broken booth components and changes to the parameters different from those set by the factory, must be made with the “Power Console” software available on request from **Automatic Systems**.

The “Power Console” program has been created to manage the **Automatic Systems** booth functions, of the Single board type.

This program works only with a hardware key. Should you need one, please contact **Automatic Systems** technical assistance service.

This program communicates with the booth using a serial door on the PC through a RS232/RS485 converter.

In order to work the software needs the following kit:

- RS232/RS485 converter.
- Converter cable DB9 female, DB9 male.
- Interface cable converter/logic 8 prong plug.
- Programming cable with button.
- Hardware key.

The minimum required to install is:

- Windows 2000 Professional.
- RAM 128 Mb.
- 100 Mb of free space on the hard disk.

Installing the “Power Console” program.

1. Click on “hdd32.exe” and choose typical installation. This will install the driver for the hardware key.
2. Install “Power Console”.

For instructions on how to use the “Power Console” software, you can request the handbook by calling **Automatic Systems technical assistance service.**

For metal detector maintenance or to change the parameters set by **Automatic Systems you must request the operating manual or contact **Automatic Systems** assistance service.**



ATTENTION: If a system error called “ENCODER ERROR” appears on the input status screen, while opening the program, this could mean that:

- The power supply of the motors is inverted.
- Counting of the encoder rotation stage is inverted.
- Some type of hindrance prevents the doors to move toward the closed position.

3.1. COMPUTER CONNECTION DIAGRAM - MAIN BOARD

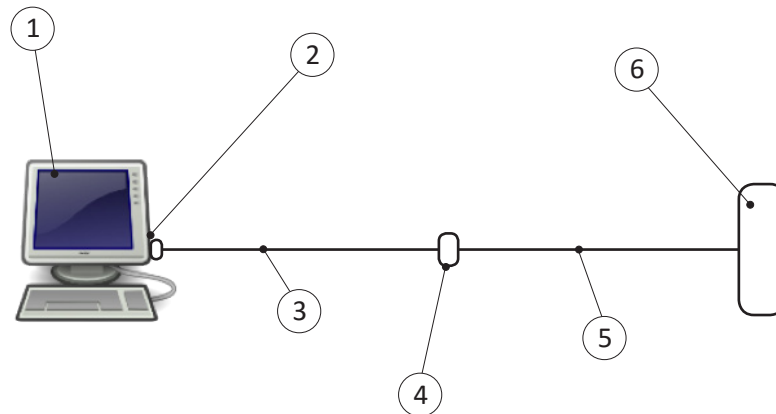

| REP. | PARTICULARS |
|------|--|
| 1 | PERSONAL COMPUTER |
| 2 | HARDWARE KEY |
| 3 | SERIAL CABLE DB9 FEMALE, DB9 MALE |
| 4 | RS232 / RS485 CONVERTER |
| 5 | INTERFACE CABLE CONVERTER - LOGIC 8 PRONG PLUG |
| 6 | MAIN BOARD |

3.2. COMPUTER CONNECTION PROJECT DIAGRAM - METAL DETECTOR

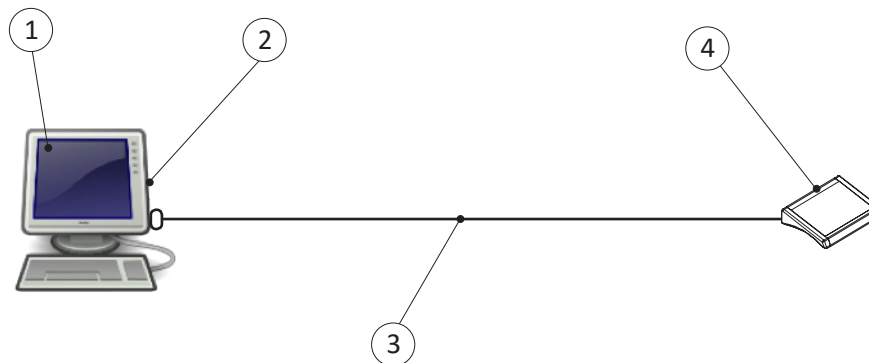

| REP. | PARTICULARS |
|------|---|
| 1 | PERSONAL COMPUTER |
| 2 | HARDWARE KEY |
| 3 | SERIAL CABLE RS232 - DB9 FEMALE, DB9 MALE |
| 4 | METAL DETECTOR MAIN BOARD |

The information contained in this document is the property of Automatic Systems and is confidential. The recipient shall refrain from using this information for any purpose other than the use of the products or the execution of the project to which it refers and from communicating it to third parties without prior written agreement of Automatic Systems. The document is subject to change without notice.

AUTOMATIC SYSTEMS BELGIUM - HQ

Email: asmal@automatic-systems.com

Tel.: +32.10.23 02 11

Fax: +32.10.23 02 02

Belgium

Wallonia-Brussels

Tel: +32 70 22 44 66

Fax: +32 10 86 22 90

Email: helpdesk.be@automatic-systems.com

Canada

Tel: +1 450 659 0737

Fax: +1 450 659 0966

Email: helpdesk.nam@automatic-systems.com

Deutschland

Tel: +49 2303 943295

Email: helpdesk.de@automatic-systems.com

Spain

Tel: +34 93 478 77 55

Fax: +34 93 478 67 02

Email: helpdesk.es@automatic-systems.com

United States

Tel: +1 450 659 0737

Fax: +1 450 659 0966

Email: helpdesk.nam@automatic-systems.com

Belgium

Flanders

Tel: +32 70 22 44 66

Fax: +32 3 88 700 76

Email: dnv.be@automatic-systems.com

China

Tel: +86 512 5383 0561

Email: helpdesk.cn@automatic-systems.com

France

Tel: +33 1 30 28 95 53

Email: helpdesk.fr@automatic-systems.com

United Kingdom

Tel: +44 (0) 1604 654 210

Fax: +44 (0) 1604 654 110

Email: helpdesk.uk@automatic-systems.com